

Production Motors for Turbo-Compressors

300KW 20,000 RPM - 24,000 RPM

mSpWRF 28/15-4 VPI

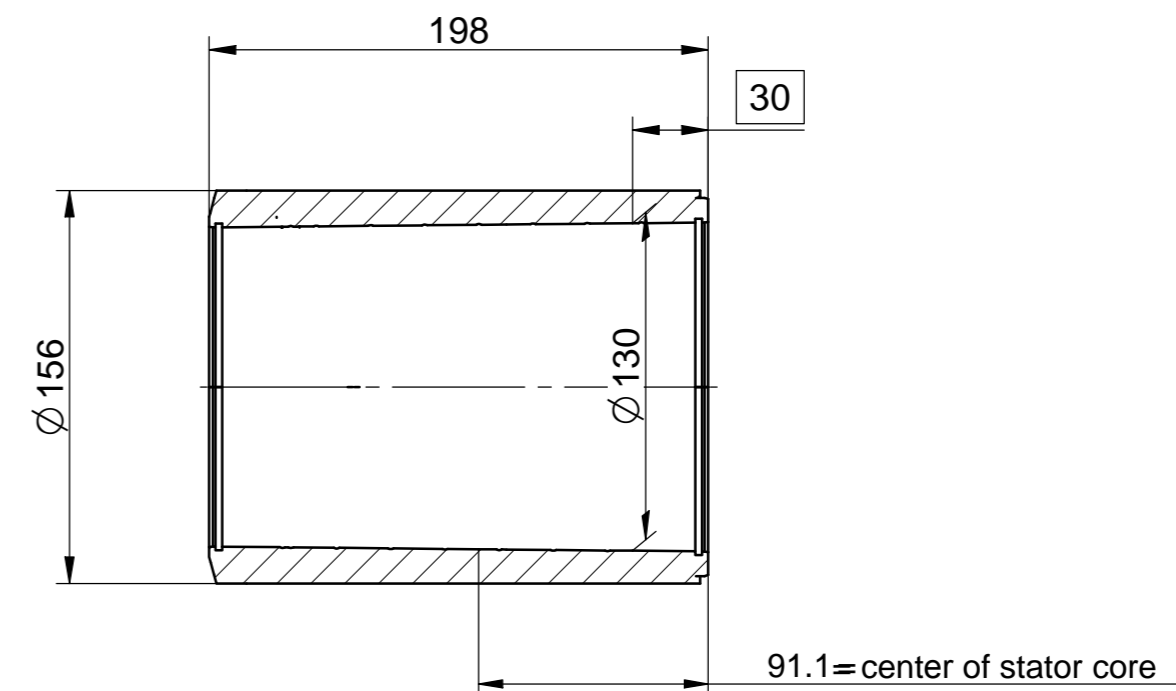
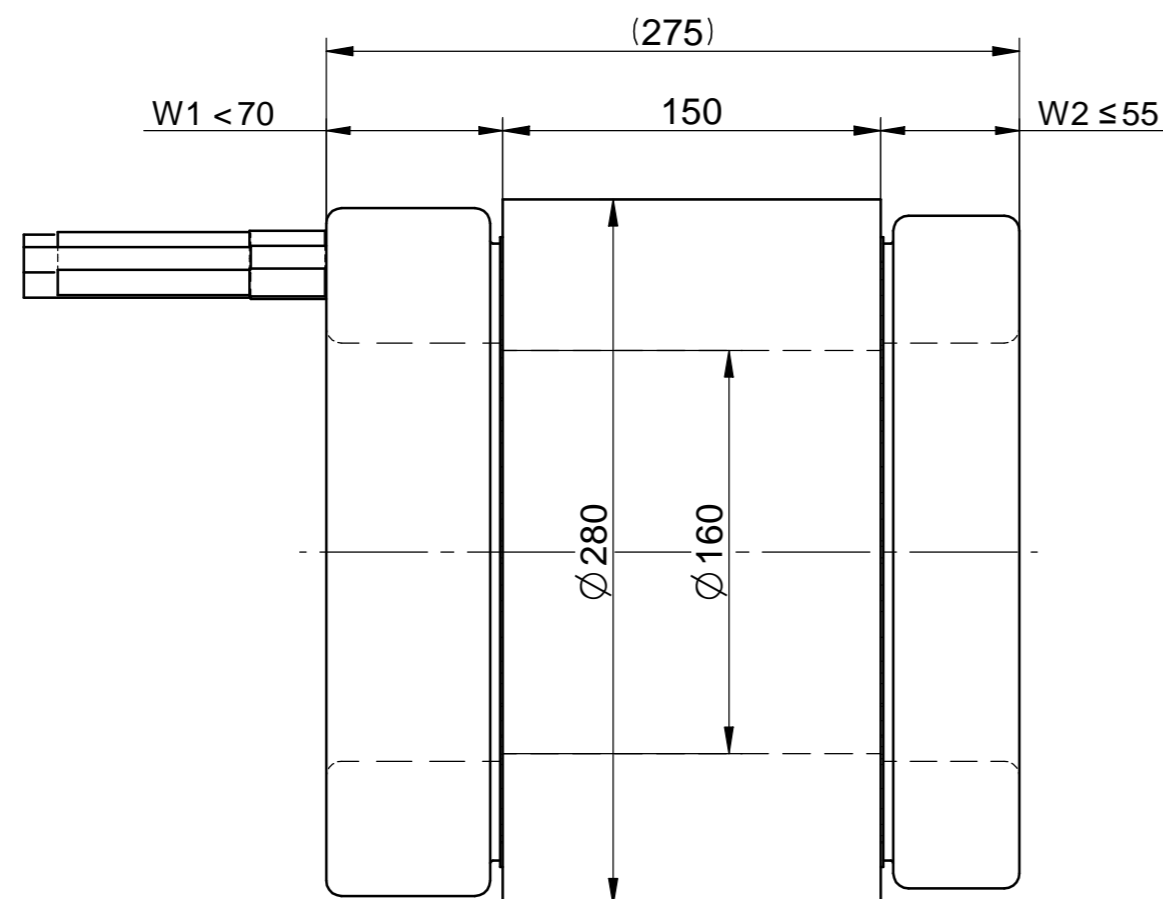

Specifications				
Speed	n	20'000	24'000	rpm
Frequency	f1	666	800	Hz
Power	P1	300	300	kW
Voltage	U1	390	460	Vrms
Current	I1	490	410	Arms

Notes:

- 4-pole stator & PM-rotor set
- VPI end winding for refrigerant cooling
- Efficiency with sinusoidal current supply > 97%
- H-class insulation system for winding temperatures up to 180°C (356°F)
- type and number of temperature probes: customer specified
- cable outlet configuration: customer specified
- suitable for operation in R134A and R245 refrigerants
- PM-rotor with tapered ID and carbon fiber retaining sleeve
- rotor mounted by pushing onto tapered shaft (no heat required)
- maximum structural rotor speed: Nmax = 24,000 RPM
- suitable for motor and generator applications

Optionally available: Cooling jacket system for effective liquid cooling

